

# Typical System Addressing

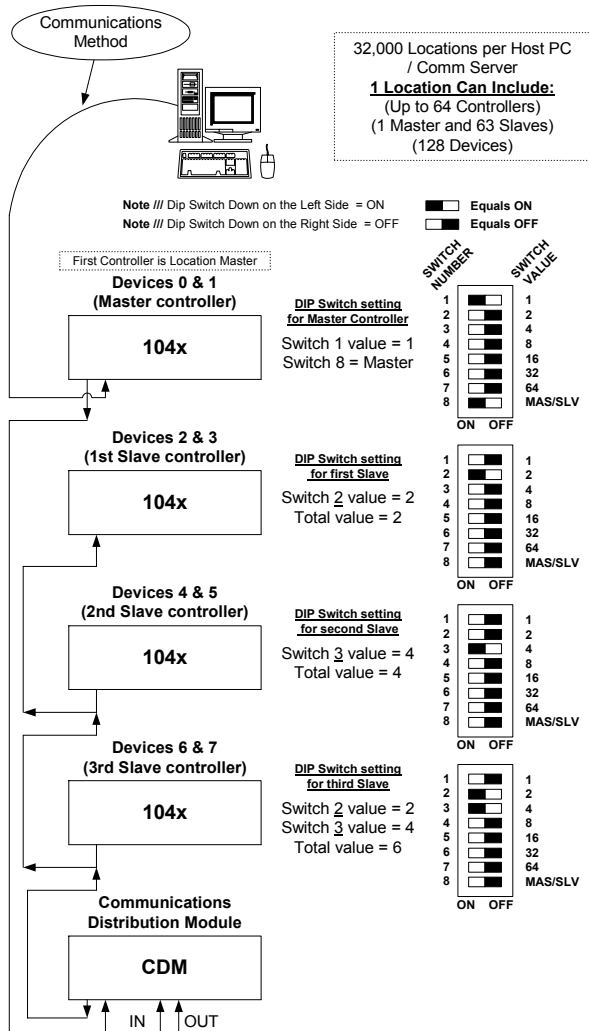

## Direct Connect Location # 1

Use this Diagram to assist you in setting the address switches on each DSX Controller.

- Turn the switches on and Add the values.
- The slave device address is always an even number.
- Side A = even number set by the switches.
- Side B = next highest odd number.
- The Master is always device address 0 & 1.
- To set the Master address above 127 set switches 1-7 off and set the address using KB2CW.exe from the WinDSX directory.
- When using the Template Database set the address switches 1 & 8 to the ON position.

# Installing WinDSX Software

1. Before Installing the Software you must login as a user with full administrator rights. The PC should have Windows NT™ 4.0 with at least service pack 6, XP™ or Windows 2000 Professional™ with Service Pack 2.
2. On a Single PC load the software according to step 3. For a Local Area Network skip to step 4.
3. To load the software, place the WinDSX CD in the CD-ROM Drive. Select "My Computer" on the desktop then right click on the CD-ROM Drive and select explore. Navigate to the Install Directory. Open the Install Directory and double click on Setup.exe. Follow the prompts and allow setup to install the software into the C:\WinDSX directory. Skip to step 6.
4. If this is to be loaded on more than one PC all Workstations must have a Drive Mapped to the location of the shared database resource. The operator doing the software installation needs full administrator rights in their password login for the PC they are working on and the location of the shared database resource.
5. The Software must be installed on each PC that is to run the WinDSX program. If this system is to use a Dedicated File Server (a PC that is not manned or used directly by an operator) the software should be loaded to the File Server first. The Software is then loaded on each Workstation that is to run WinDSX. Follow the software installation instructions in step 3.
6. When the software is loaded on each PC be sure that the first time you run the Database program (DB.EXE) that you set the DataBase Path on each PC to the location of the shared database resource. Also be sure to assign the PC a unique Workstation Name and Number other than 1.
7. If this system is going to use one of the Workstations as the shared database resource then this PC should be the first one to be loaded and configured.
8. During the installation if the Setup program states the PC must be reset after completion, do so after the software installation by going through the normal shut down and restart procedure for Windows™. To shut down and restart the PC, close all programs, select "Start" then select "Shutdown" followed by "Restart".
9. If this PC is not or will not be connected to a Local Area Network use the MS Loopback Adapter and a TCP/IP address of 127.0.0.1.

# Updating WinDSX Software

1. For Software Updates, first make a backup under System/Setup in the DataBase program. Next the program must be shut down and exited on all PCs. The Comm Server must also be shut down.
2. If this system is using a Dedicated File Server the software must be un-installed and re-installed on the Server first.
3. To un-install WinDSX select "Start" then "Settings" then "Control Panel". From "Control Panel" select "Add/Remove Programs". Then click on "WinDSX" and click on "Remove." Allow for all shared files to be removed if you are going to re-install WinDSX. If WinDSX is not to be re-installed do not remove any shared files. If the un-install program states that certain \*.zip, and \*.mdb files cannot be removed because they no longer exist just Click on OK and continue. This is normal and nothing to worry about.
4. Once the software is un-installed on the server it is ready to be re-installed. To load the software, place the WinDSX CD in the CD-ROM Drive. Select "My Computer" on the desktop then right click on the CD-ROM Drive and select explore. Navigate to the Install Directory. Open the Install Directory and double click on Setup.exe. Follow the prompts and allow setup to install the software into the C:\WinDSX directory or instruct setup of the desired directory.
5. When the software is loaded on a File Server, use Explorer to locate and run the DB.EXE program located in the same directory on the server. Once the DB.EXE program is finished updating the database it will leave you on the DataBase Main Menu. Select File then Exit.
6. Repeat steps 3 & 4 for all Workstations and Comm Server.

## Serial Communication Ports

1. The onboard Serial Ports to be used with WinDSX must have the following parameters in both Windows™ and in the CMOS (BIOS) Setup of the PC.
  - Baud Rate – 9600
  - Data Bits – 8 / Stop Bits – 1
  - Parity – None
  - Flow Control – None
  - Comm Port 1 = Address 3F8 IRQ 4
  - Comm Port 2 = Address 2F8 IRQ 3



**DSX Access Systems, Inc.**

## DSX-1048 Quick Reference Card

**DSX Access Systems, Inc.**  
 10731 Rockwall Road, Dallas, Texas 75238  
 800-346-5288 Voice 888-419-8353 Voice  
 214-553-6147 FAX www.dsxinc.com

