

i-Pass

Door Elevator and Carpark Controller

Overview

The i-Pass door, elevator and car park controller provides access control of doors, elevators and boom gates up to a maximum of 16 readers. Any of these readers may be in an elevator car, providing floor by floor access control up to a maximum of 32 floors. Floor release inputs are also used to give tenants the ability to allow visitors to access their floor.

Installation

Door access control comprises of a reader, an output to be released, and optionally a Request to Exit button, a door sensor and door forced and door held alarm outputs. Elevator access control comprises a reader, an output per floor, and optionally a floor release input per floor. The I-PASS control unit has 16 inputs and 16 relay driver outputs.

Car park access control comprises of a reader, optionally a reader enable loop and an output. Additional inputs and outputs located remotely from the I-PASS utilise the DIDO (Digital Input, Digital Output) module, which is connected to the same RS485 bus as the readers.

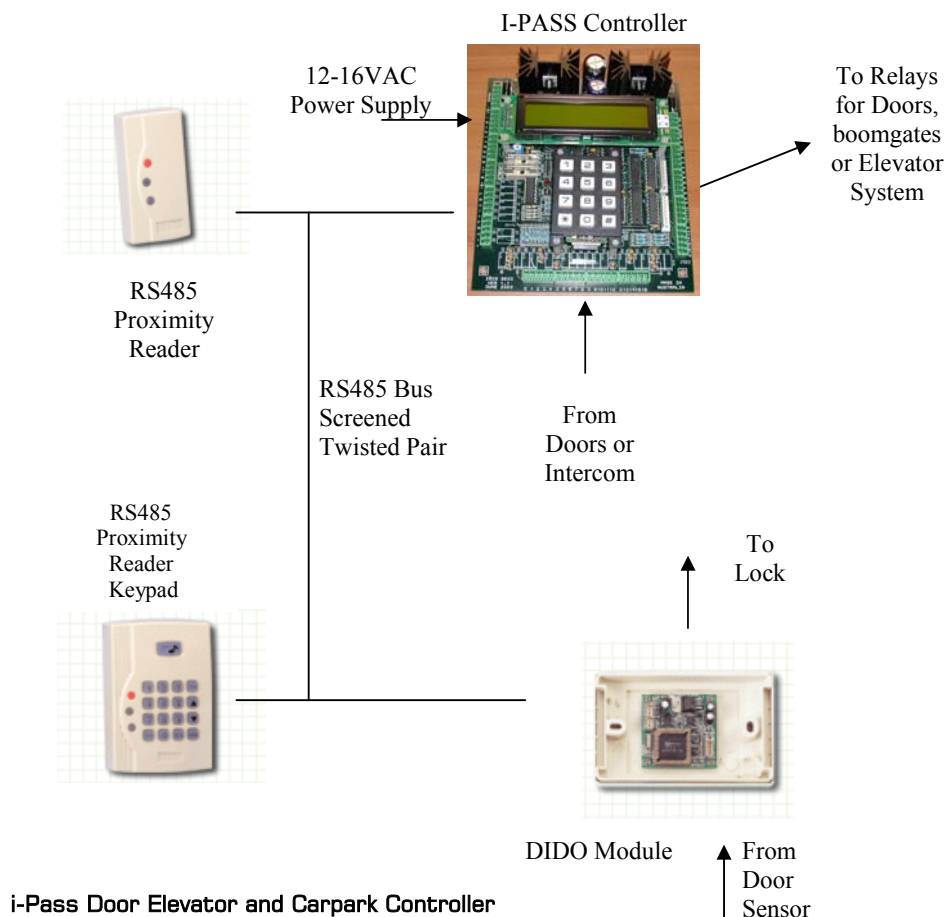

Outputs

Two types of output are available on the I-PASS controller. Sixteen open-collector relay driver outputs are provided, as well as two dry-contact single pole change over relays. Each open-collector relay driver output of the I-PASS controller can sink up to 120mA, provided adequate ventilation is provided. These outputs can be used to drive relays to switch higher currents, or directly for audible alarms etc. The onboard relays are rated at 1 amp, 24VDC.

Additional remote outputs can be connected using the DIDO (Digital Input, Digital Output) modules connected to the RS485 bus. Outputs on the DIDO module are relay contacts, rated at 1 amp 24VDC.

See **Appendix B** for detailed wiring.

Inputs

The TTL/CMOS-compatible inputs (if fitted) on the I-PASS expect to monitor a dry contact. Internal input bias resistors provide the pull-up. A low-pass filter also blocks incoming voltage spikes.

Additional remote inputs on the DIDO module require a dry contact to monitor.

See **Appendix B** for detailed wiring.

Operation

The I-PASS controller can be programmed via the onboard keypad and LCD display (if fitted), or through a RS232 connection to a PC running the I-PASS PCLink. Operation is identical for either mode, as the PCLink software merely remotes the keyboard and display to the PC.

The I-PASS screen will normally display system events as they occur. To view previous events, scroll up or down using the UP (0) or DOWN (9) keys. Hitting ESC (*) will immediately return to the most recent transaction. Hitting any other key will display the logon screen, waiting for a 5 digit password to be entered. At this time, the system date and time will be displayed. Entering a valid password will log the operator in to the programming screen. The default password is 12345.

Programming consists of moving through the menus, navigating by the Up or Down keys, the ENT (#) key and the ESC (*) key. Press the Up or Down key to select the required menu item, and press ENT. Move back through the menus using the ESC key.

Any time that the programming screen shows a menu number, any other option at the same nesting level can be selected by pressing the appropriate menu number. For example, when first logged on, the menu displays "1. Cardholders". Pressing ENT selects cardholders and displays the Cardholder options. However, if '3' is pressed, the screen changes to "3. System Setup".

Whenever a numeric input is required, the existing value is displayed as a prompt. To accept that value, press ENT. Otherwise type in the required value. Key presses may be removed by using the ESC key. If no more keys have been entered for that option, the option is aborted. **Y/N entries** are done using the **1(Y)** and **2(N)**.

When no keyboard activity has occurred for the keyboard timeout, the system automatically logs off.

Display

The LCD display shows the transactions as they occur scrolling up (the most recent transaction being the bottom line. The columns are:

Status	What type of event occurred
Time	When did the event occur
Point	Where did the event occur
Action	What actually occurred

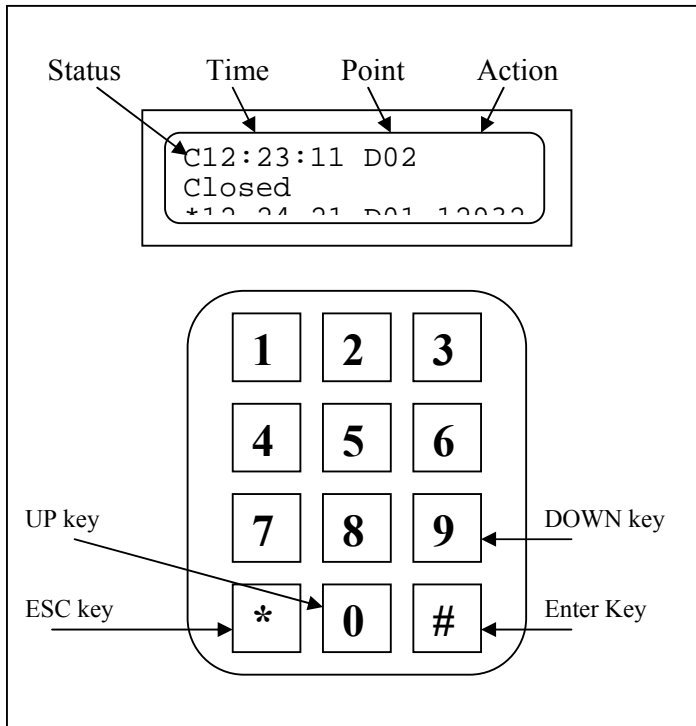

Possible status codes are:

*	Valid card read
#	Valid PIN entry
Aa	Antipassback Violation
Ee	Reader not Enabled
Tt	Card out of Timezone
Dd	Card not valid at this Door
S	Incorrect Site Code
Vv	Card not Valid at this site
H	Door Held
F	Door Forced
C	Door Closed after Held or Forced
X	Request to Exit Button pressed
U	Door / Floor Unlocked Manually
K	Door / Floor Locked manually
Y	Module Communications alarm
L	Lift Floor Release
Z	Timezone Change
O	Operator Logon
R	Controller Reset
B	Daylight Savings Change

Note: Lower case indicates PIN entry

Programming Tree

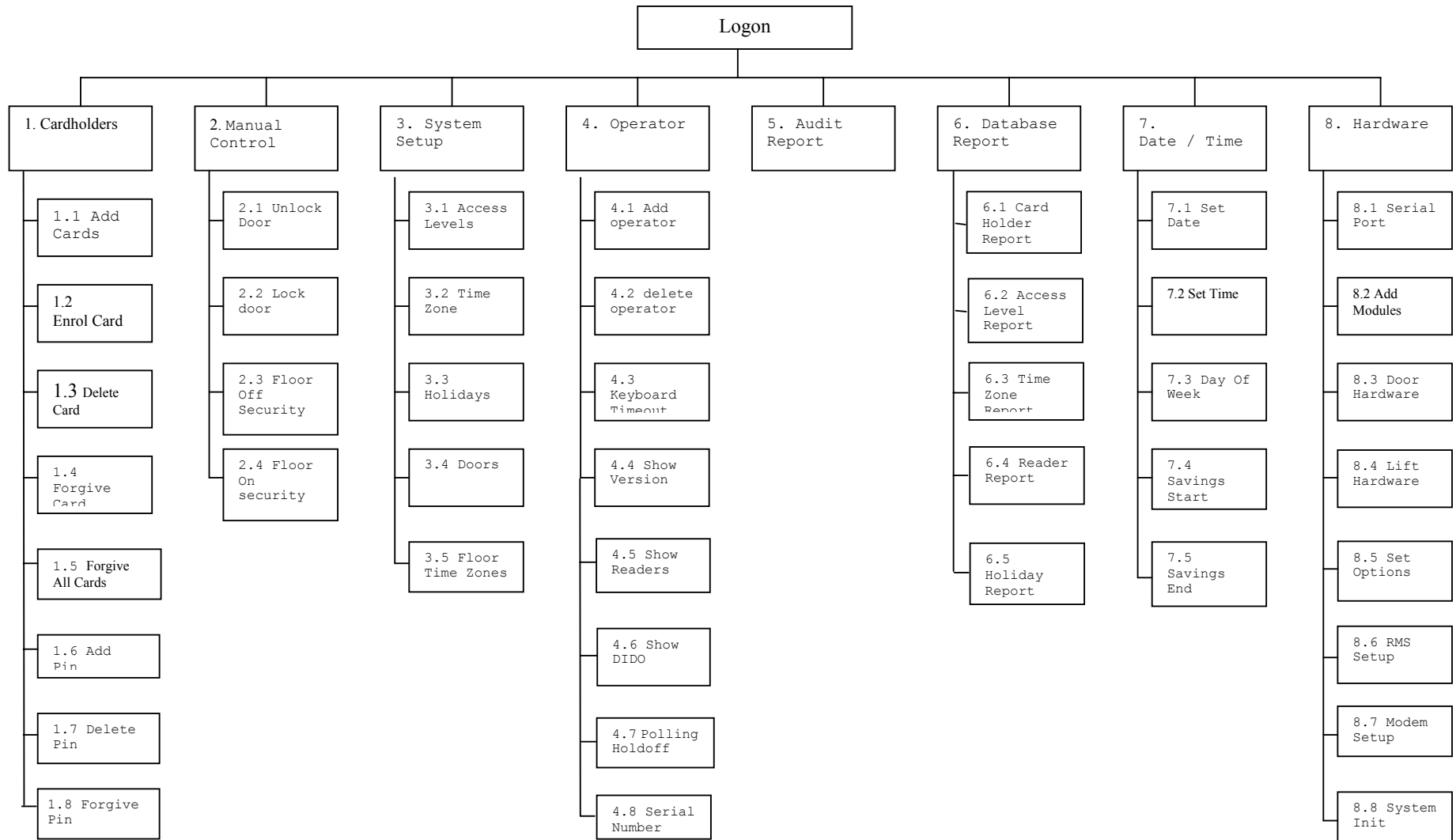

System Installation and Commissioning

Before programming please read through the following section which can also be used a check list. System commissioning is best done in the following sequence.

1. Determine the number of readers and keypads to be installed, and the power requirements for them. The I-PASS can supply up to 500mA for the readers, and up to 500mA for locking devices etc. If additional power is required an external 12V DC supply can be used, and the I-PASS powered through the Battery connection, and the AC input not used.
2. Determine if any DIDO modules are required. DIDOS allow additional inputs and outputs to be located away from the I-PASS controller. For example, a remote door may be controlled using a reader and DIDO module located near the door, with a local power supply. The DIDO can provide the lock release output and the door monitoring and request to exit inputs.
3. All devices are wired in parallel to the RS485 port on the I-PASS. Ensure that the 4R+ wires on all devices are connected to the T+ AND R+ on the I-PASS, and that the 4R- wires are connected to the T- and R- terminals.
4. Set the Day, Date and Time in Menu item 7.
5. Add the readers and keypads to the I-PASS database in Menu item 8.2. The keypads need to be defined as keypad units even if they are only being used as card readers.
6. Ensure that all readers are communicating with the I-PASS by checking the status using Menu item 4.5 and 4.6
7. Determine what time zone combinations are required for the site, and define the time zones. Time zone 0 is always off and Time zone 1 is always on. These cannot be edited.
8. For readers on doors, define the output relay, and any additional inputs and outputs required. If Request to Exit buttons are defined, check that they release the relevant relay. If the door is required to unlock on time schedule, add the relevant time zone to the door setup.
9. For readers on Boom gates, define the output relay and reader enable input if needed. The reader enable input can disable readers if a vehicle is not present over the detect loop. Select antipassback if required.
10. For readers in lifts, define the outputs for each lift car for each floor. Floor release inputs can also be defined, so that a request from a floor, usually from an intercom system, can release security on all lifts to that floor for a time.
11. Define the Access Levels. Access Levels are a unique combination of readers that a user can access, and which floors can be accessed, and during which time zone. By default, Access Level 0 gives access to all readers and all floors all the time.
12. Add cardholders and PIN holders to the I-PASS. Valid cards should release the door for the Latch time
13. If the RMS interface is being used, configure through Menu item 8.6
14. Backup all data to a PC through the I-PASS software.

Programming Menu – Standalone Controller

This programming menu is displayed in the menu format of the i-Pass controller and does not mean that programming must begin in this manner.

Note: You must be logged in as an operator before you can be in the programming menu. See “Operation” above on how to login.

1. Cardholder

1.1 Add Cards

Add Card from 1 (enter first card number)

Add Card 1 (first card number taken from above) To 1 (enter last card number)

Site Code 1 (enter site code)

A/L 0 (enter access level number, note: access level 0 is master access level)

```
Add Card      Site 2
00002-000002      A/L 0
```

LCD or i-Pass PCLink Example

This function is used to add cards to the I-PASS, or to change the Access Level of an existing card. The first and last card numbers are entered. If the first card exists, the Site Code is displayed, else the Site Code must be entered. Once the Site Code is entered, the existing Access Level for the first card, if any, will be displayed as the default value for the Access Level. If any cards are already existing in this range, they will be overwritten with the new Site Code and Access Level.

1.2 Enrol Cards

Enrol at reader 1 (enter the reader number card is to be enrolled at)

Level 0 (enter access level number)

Card ?????? (enter card number)

```
1.2 Enrol Cards
Level 00  Card ??????
```

LCD or i-Pass PCLink Example

This function is used to read valid cards into the I-PASS, and assign them an Access Level. The card number enrolled is displayed when the card is badged at the specified reader.

1.3 Delete Card

Card No 1 (enter card number to be deleted)

Del N (default is N (NO), press 1 on numeric keypad to change to Y(YES))

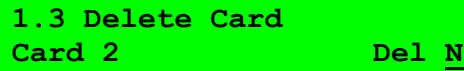

1.3 Delete Card
Card 2 Del N

LCD or i-Pass PCLink Example

Delete Card permanently removes a card from the I-PASS database.

1.4 Forgive Card

Card No 1 (enter card number)

This function allows a cardholder to travel in either direction for their next access through an AntiPassback enabled reader.

1.5 Forgive All

Confirm N (default is N(NO), press 1 on keypad to change to Y(YES))

This function allows all cardholders and PIN users to travel in either direction for their next access through an AntiPassback enabled reader.

1.6 Add PIN

Pin 1111 (enter PIN number)

A/L 0 (enter access level to assign to PIN number)



Add Pin
Pin 1111 A/L 0

LCD or i-Pass PCLink Example

Add Personal Identification Numbers to be used with Keypad readers. Once the PIN is entered, the existing Access Level if any is displayed for modification.

1.7 Delete PIN

Pin No 1111 (enter PIN number to be deleted)

Del N (default is N(NO), press 1 on keypad to change to Y(YES))

Delete PIN permanently removes a PIN from the I-PASS database.

1.8 Forgive PIN

Pin No 1111 (enter PIN number)

This function allows a PIN user to travel in either direction for their next access through an AntiPassback enabled PIN pad.

2. Manual Control

2.1 Unlock Door / Lift

Door No 01 (enter door or lift reader number)

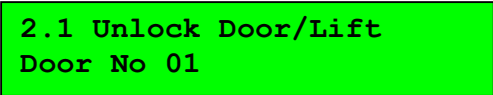

2.1 Unlock Door/Lift
Door No 01

LCD or i-Pass PCLink Example

Unlocks a door or all floors associated to one(1) lift until locked again either by using Function 2.2 below, or by the Timezone assigned to the door ending.

2.2 Lock Door / Lift

Door No 01 (enter door or lift reader number)

Locks a door or all floors associated to one(1) lift until locked again either by using Function 2.1 above, or by the Timezone assigned to the door ending.

2.3 Floor De-secure

Floor No 01 (enter floor number)

Takes a floor off security until secured again either by using Function 2.4 below, or by the Timezone assigned to the floor ending. If there is more than one lift, the same floor number in all other lifts will also be taken off security.

2.4 Floor Secure

Floor No 01 (enter floor number)

Puts a floor on security until de-secured again either by using Function 2.3 above, or by the Timezone assigned to the floor beginning. If there is more than one lift, the same floor number in all other lifts will also be put on security.

3. System Setup

3.1 Access Levels

Access Level 01 (enter access level number, note that 0 is master access level)

Timezone 01 (enter timezone number, note that timezone 00 is no time and
timezone 01 is 24 hour)

```
3.1 Access Level    01
Timezone           01
```

LCD or i-Pass PCLink Example

Doors 0-7 NNNNNNNN (press 1 for Y=Yes, 2 for N=No (Default) on keypad
to assign which doors will be valid for this access
level)

```
3.1 Access Level    01
Doors 0-7          NNNNNNNN
```

LCD or i-Pass PCLink Example

Doors 8-15 NNNNNNNN (press 1 for Y=Yes, 2 for N=No (Default) on
Keypad to assign which doors will be valid for this
access level)

Flrs 0-7 NNNNNNNN (press 1 for Y=Yes, 2 for N=No (Default) on keypad
to assign which Floors will be valid for this access
level)

```
3.1 Access Level    01
Flrs 0-7           NNNNNNNN
```

LCD or i-Pass PCLink Example

Flrs 8-15 NNNNNNNN (enter options as above)

Flrs 16-23 NNNNNNNN (enter options as above)

Flrs 24-31 NNNNNNNN (enter options as above)

ABP Exempt N (press 1 for Y=Yes, 2 for N=No (Default))

This function is used to define where and when an Access Level allows access. Select the Access Level, then choose a timezone during which this Access Level should allow access. Set the Access to *Yes* or *No* for each door and floor in the installation. If the Access Level has its *Antipassback Exempt* flag set to *Yes*, then any cardholder on that Access level will be able to travel through antipassback doors regardless of which direction they last travelled.

3.2 TimeZone

Timezone 02 (enter the timezone number you want to create.

Note: Timezone 00 is a system Timezone and cannot be Edited. Timezone 01 is by default set to 24 x 7)

```
3.2 TimeZone      02
07:00-18:00      _YYYYYYY
```

LCD or i-Pass PCLink Example

00:00-00:00 (enter start time and end time by pressing numeric keypad)

NNNNNNNN (enter which days timezone is to be valid
press 1 for Y=Yes, 2 for N=No (Default))

(in the example above the timezone will be valid from 7am to 6pm on everyday of the week including holiday periods)

Each timezone consists of three periods, each of which can be active on any day, including Holidays. The timezone is active from the start time to the end of the minute entered as the end time. The first day of the week is Sunday, the seventh day is Saturday and the eighth day is a Holiday.

3.3 Holidays

3.3.1 Set Holiday

00/00/00 (enter holiday that needs to be set)

```
3.3.1 Set Holiday
                28/09/04
```

LCD or i-Pass PCLink Example

Up to 16 holidays may be entered in the I-PASS.

3.3.2 Clear Holiday

00/00/00 (enter holiday that needs to be cleared)

Old Holidays must be deleted to allow room for new ones.

3.3.3 List Holidays

Use the Up (0) and Down (9) keys to view all Holidays defined in the I-PASS.

3.4 Doors

Door No 00 (a door can also be considered as a relay(channel). Here you can define the characteristics of that door. Enter the door number you want to work with)

Latch Time 4 (Enter the number of seconds that the door should remain unlocked when a valid card is read. Valid values are 1 to 64800 (18 hours))

```
Door No  00
Latch Time  4
```

LCD or i-Pass PCLink Example

Shun Ttime 30 (Enter the number of seconds that the door can remain open after the latch time before a Door Held alarm is generated. This time is also used for Floor Release inputs, to take a floor off security to allow a visitor to gain access to a floor.)

```
Door No  00
Latch Time  4
```

LCD or i-Pass PCLink Example

Time Zone 02 (enter the timezone number previously created)

The door controlled by this reader will be unlocked while this timezone is active. If the reader is in a Lift, then that lift will be off security while the timezone is active.

```
Door No  00
Time Zone  02
```

LCD or i-Pass PCLink Example

Read Before Unlock N (press 1 for Y=Yes, 2 for N=No (Default))

If set to “Yes” the door controlled by this timezone will not unlock until a valid card has been read by the reader. The door will then stay unlocked until the timezone ends.

APB 2No 1In 0Out 2 (enter the anti-passback setting for the door:

2 = No anti-passback

1 = The door will be set to an IN door

0 = The door will be set to an OUT door)

Set whether the reader allows access into or out of the antipassback area, or is not involved in antipassback.

3.5 Floor Time Zones

Flr 00 (enter the floor number to be assigned a timezone)

TimeZone 00 (enter the timezone to be assigned to that floor. Note: Timezone 00 is a system Timezone and cannot be Edited. Timezone 01 is by default set to 24 x 7)

```
Door No    00
Time Zone           02
```

LCD or i-Pass PCLink Example

Select which timezone each floor is set to. While the timezone is on, the floor will **not** be secure.

4. Operator

4.1 Add Operator (Operator 0 Only)

Add Operator # 1 (enter the next operator number)

Password _ (enter the password which consists of 5 digits only)

```
4.1 Add Operator    #1
Password 12345
```

LCD or i-Pass PCLink Example

Note: Operators can only be added by Operator 0

4.2 Delete Operator (Operator 0 Only)

Delete Operator No 0 (enter the operator number to be deleted)

```
4.2 Delete Operator
Delete Operator No  1
```

LCD or i-Pass PCLink Example

Note: Operators can only be deleted by Operator 0

4.3 Keyboard Timeout

Set the number of seconds after the last key press that the I-PASS will automatically log off the operator. Valid range is 10 to 600 seconds.

4.4 Show Version

Shows the current version of the i-Pass controller. This may be required when requesting assistance.

7. Set Date and Time

7.1 Set Date

Set the system date.

```
Enter Date          19/10/04
```

LCD or i-Pass PCLink Example

7.2 Set Time

Set the system time in 24 hour mode.

```
7.2 Set Time      10:53:04
```

LCD or i-Pass PCLink Example

(in the example above 10 = hour, 53 = min and 04 = seconds)

7.3 Day Of Week

Set the day of the week (use Up = 0 and Down = 9)

```
7.3 Day of Week  
Tuesday          _
```

LCD or i-Pass PCLink Example

7.4 Savings Start

The system clock will be advanced one hour at 2:00am on this date for sites requiring daylight savings feature.

```
7.4 Savings Start 30/10/03
```

LCD or i-Pass PCLink Example

7.5 Savings End

The system clock will be wound back one hour at 3:00am on this date for sites requiring daylight savings feature. This date will then be cleared.

```
7.4 Savings End  30/03/04
```

8. Hardware (Operator 0 Only)

8.1 Serial Port

Baud Rate 9600 (enter the required Baud Rate then press the # key)

```
8.1 Serial Port
Baud Rate 9600
```

LCD or i-Pass PCLink Example

Bits (7/8) 8 (enter the number of bits required then press the # key)

```
8.1 Serial Port
Bits (7/8) 8
```

LCD or i-Pass PCLink Example

Parity 0=N, 1=E, 2=O 0

(0=N means No Parity, 1=E means Even Parity, 2=O means Odd Parity.

Enter either 0, 1 or 2 depending on our configuration then press the # key)

```
8.1 Serial Port
Parity 0=N, 1=E, 2=O 0
```

LCD or i-Pass PCLink Example

Printer N (Select if port connects to Printer or PCLink)

(press 1 for Y=Yes, 2 for N=No (Default PCLink) then press the # key)

```
8.1 Serial Port
Printer N
```

LCD or i-Pass PCLink Example

Note: PCLink Software requires 9600 Baud, 8 Bits, No Parity, No modem.

Real Time Audit N (Printer can be set for reports or real-time Audit trail)

(press 1 for Y=Yes, 2 for N=No (Default PCLink) then press the # key)

```
8.1 Serial Port
Real Time Audit N
```

LCD or i-Pass PCLink Example

Modem N (press 1 for Y=Yes if modem is being used, 2 for N=No)

8.2 Add Modules

8.2.1 Add Reader Module

Rdr 00 (enter the reader number, readers can begin at 0)

S/N (enter the serial number from the back of the reader or wiegand module if being used instead)

```
8.2.1 Reader Module
Rdr 00 S/N 03305669
```

LCD or i-Pass PCLink Example

Keypad (Y/N) N (if keypad reader is being used press 1 for Y=Yes else else leave as N=No (Default))

```
8.2.1 Reader Module
Rdr 00 Keypad (Y/N) N
```

LCD or i-Pass PCLink Example

Each reader has an eight digit serial number, that is used to distinguish one from the other. Unused readers should have their serial number left blank. Valid reader numbers are 0 to 15. Keypad readers need to be identified.

8.2.2 Onboard Reader

The system is capable of having two wiegand readers directly connected on board. To enable the readers you must choose yes from the menu.

Reader 1 Door 01 (enter the door number that this reader will control)

Reader 2 Door 02 (enter the door number that this reader will control)

Note: Door configuration is explained in section 8.3.

Reader Wiegand Y/N N (press 1 for Y=Yes (enable onboard reader) else leave as N=No (Default))

```
8.2.2 Onboard Reader
Reader Wiegand (Y/N) N
```

LCD or i-Pass PCLink Example

Note: When wiegand readers are used the system is still only capable of having a total of 16 readers regardless of the reader being wiegand or RS485 format.

8.2.3 DIDO Module

DIDO 00 (enter the DIDO unit number)

S/N _ (enter the serial number of the DIDO module. If using an i-Pass-DIDO-4 module the 8 digit serial number can be found on the PCB. If using an i-Pass-DIDO-16 the serial number can be found on the back of the unit.)

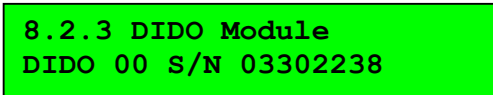

8.2.3 DIDO Module
DIDO 00 S/N 03302238

LCD or i-Pass PCLink Example

16 Chan? N (if you are using an i-Pass-DIDO-16 press 1 for Y=Yes, else leave as N=No (Default))

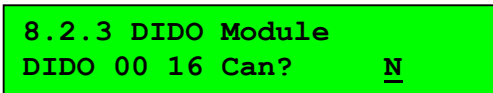

8.2.3 DIDO Module
DIDO 00 16 Can? N

LCD or i-Pass PCLink Example

Each Digital Input / Digital Output Module has an eight digit serial number, that is used to distinguish one from the other. Unused DIDO's should have their serial number left blank. Valid DIDO numbers are 0 to 15.

8.3 Door Hardware

Door hardware configuration determines which outputs and input points will be used for that particular reader and/or lift. The first menu option in Door Hardware will prompt for the reader number to be configured:



Reader No 0

LCD or i-Pass PCLink Example

Once a reader value of 0-15 is entered the menu will continue to the submenu and configuration can be continued.

When configuring which outputs and inputs are to be used with a reader it must be determined from which type of controller the output/input points are being used from (**Type**), the **Unit** (only used for DIDO modules) value and **Channel** (output or input point). There are two (2) on board relays which can be used. All other points are not onboard therefore when configuring, a different type number must be specified.

Type specifies which type of board the point is connected to.

Input / Output Connected to	Type
I-PASS Controller Relay Driver Outputs (are not on board and must be connect to via ribbon cable from white connector located middle right of board)	0
I-PASS Controller Inputs (located bottom of board)	0
I-PASS Controller Relays (Onboard Relays located upper right of board)	1
DIDO Module	2

Any unwanted function can be left disabled by using Type 0, Unit 0 and Channel 0.

Unit is only used for DIDO modules and specify which module of this type that the point (output or input) is on. Valid unit values for a DIDO are 0-15.

Note: When configuring on board relays the unit value can be left at 0 as this is not being used.

Channel is which particular point (output or input) on the module that is used.

The maximum channel depends on the module type.

Module Type	Maximum Channel No	
	Input	Output
I-PASS Controller Relay Driver Outputs (are not on board and must be connect to via ribbon cable from white connector located middle right of board)		16
I-PASS Controller Inputs (located bottom of board)	16	
I-PASS Controller Relays (Onboard Relays located upper right of board)		2
DIDO4	4	2
DIDO16	16	16

Safe determines if the output is connected to a failsafe device. If so, the output is energized for secure, and de-energised for not secure.

8.3.1 Door Relay

Specify the output that the door locking mechanism is connected to.

Ty 1 (enter the type of board the point is connected to. In this case it's the onboard relays)

Un 00 (enter the Unit value if this point is used on a DIDO module else leave at 00. In this case the onboard relays are used as the Type is 1 so the Unit value can be left at 00)

Ch 01 (enter the channel number. This is the output number to be used on the Unit. In this case onboard relay 1 will be used as the point)

S N (press 1 for Y=Yes, or 2 for N=No (default). This determines if the output is connected to a failsafe device. If so, the output is energized for secure, and de-energized for not secure)

```
8.3.1 Door Relay
Ty 1 Un 00 Ch 01 S N
```

LCD or i-Pass PCLink Example

8.3.2 RTX Input

Specify the input that the request to exit button is connected. This button should be normally open. RTX Inputs are configured in much the same way as Door Relays above:

Ty 0 (enter the type of board the point is connected to. In this case it's the onboard inputs)

Un 00 (enter the Unit value if this point is used on a DIDO module else leave at 00. In this case the onboard inputs are used as the Type is 0 so the Unit value can be left at 00)

Ch 01 (enter the channel number. This is the input number to be used on the Unit. In this case onboard input 1 will be used as the point)

```
8.3.2 RTX Input
Ty 0 Un 00 Ch 01
```

LCD or i-Pass PCLink Example

8.3.3 Frame Input

Specify the input that the door monitor is connected to. The input should be normally closed, going open when the door is opened. If this opens without a valid access, a Forced Door alarm is generated. If it opens during a valid access, but does not close within the shunt time, a Held Door alarm is generated. Frame Inputs are configured in the same way as RTX Inputs above:

```
8.3.3 Frame Input
Ty 0 Un 00 Ch 02
```

LCD or i-Pass PCLink Example

8.3.4 Reader Enable

If defined, this input must be closed for any card read at the reader to be valid. Reader enable inputs are configured in the same way as RTX Inputs above:

```
8.3.4 Reader Enable
Ty 0 Un 00 Ch 03
```

8.3.5 Held Relay

This output will be energised whenever a Door Held alarm is generated. Held Relays are configured in the same way as Door Relays on the previous page.

```
8.3.5 Held Relay
Ty 0 Un 00 Ch 02 S N
```

LCD or i-Pass PCLink Example

8.3.6 Held Time

This is the number of seconds that the Door Held output will be energised when the Door Held alarm occurs. A value of 0 means that the alarm will remain energised while the door is held.

```
8.3.6 Held Time
30
```

LCD or i-Pass PCLink Example

8.3.7 Forced Relay

This output will be energised whenever a Door Forced alarm is generated. Forced Relays are configured in the same way as Held Relays above.

```
8.3.7 Forced Relay
Ty 0 Un 00 Ch 03 S N
```

LCD or i-Pass PCLink Example

8.3.8 Forced Time

This is the number of seconds that the Door Forced output will be energised when the Door Forced alarm occurs. A value of 0 means that the alarm will remain energised until the door is closed.

```
8.3.8 Forced Time
30
```

LCD or i-Pass PCLink Example

8.4 Lift Hardware

8.4.1 Floor Outputs

Door 00 (enter the reader number that will be used in the lift)

Floor O/P 01 (enter the number to be released, floors begin at 0-31. The Floor O/P value will be automatically incremented once the rest of the steps below are complete allowing to do the next floor)

Ty 2 (enter the type of board the point is connected to. In this case it's the DIDO module)

Un 1 (enter the Unit value if this point is used on a DIDO module. In this case the DIDO module used has been assigned a Unit number of 1 which was the next free available Unit number which ends at 15)

Ch 02 (enter the channel number. This is the output number to be used on the Unit. In this case relay 2 on the DIDO module will be used as the point)

S N (press 1 for Y=Yes, or 2 for N=No (default). This determines if the output is connected to a failsafe device. If so, the output is energized for secure, and de-energized for not secure)

```
Door 00 Floor O/P 01
Ty 2 Un 01 Ch 02 S N
```

LCD or i-Pass PCLink Example

Each floor of each lift has a separate output.

8.4.3 Flr Release In

Floor Release I/P 1 (enter the number of the floor to be released)

These inputs release the selected floor for the Shunt time of that door. This is usually used in apartment complexes, where the intercom can release a floor to allow a visitor to access a floor. Inputs points can be defined in much the same way as the Floor Outputs in the steps above.

```
Floor Release I/P 01
Ty 2 Un 01 Ch 02
```

LCD or i-Pass PCLink Example

8.5 Set Options

The I-Pass controller can have various options enabled or disabled. These are

1. RMS Caravan Park Software Interface
2. Modem support
3. 16 Reader support rather than 2
4. Lift Control
5. Onboard Keypad.

These options are normally set when the board is shipped from the factory. If any of these options need to be changed, then a number is displayed. This number needs to be changed to an appropriate number to enable these options. This will require contacting the manufacturer whilst on site.

8.6 RMS Setup

8.6.1 Enable RMS

Enabling the RMS interface sends all card reads and PIN entries to the RS232 port for validation by the PC software.

8.6.2 Pad with 0

Card numbers have a leading 0 to make them 6 digit.

8.6.3 Pad with

Card numbers have a trailing # to distinguish from PIN entry

8.6.4 RMS Site No

Set the Site No that all cards must match to use the RMS Interface

8.7 Modem Setup (Future)

8.7.1 Enable Modem

8.7.2 Modem Speed

8.7.3 Init String

8.8 System Initialize

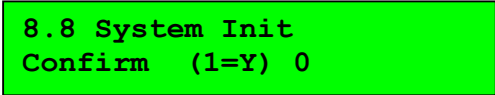

```
8.8 System Init
Confirm (1=Y) 0
```

LCD or i-Pass PCLink Example

This will return the I-PASS to its initial state, with no readers, cards etc defined.

NOTE! THIS WILL DELETE ALL CARDS!!

Appendix A – PCB Connection Wiring Diagram

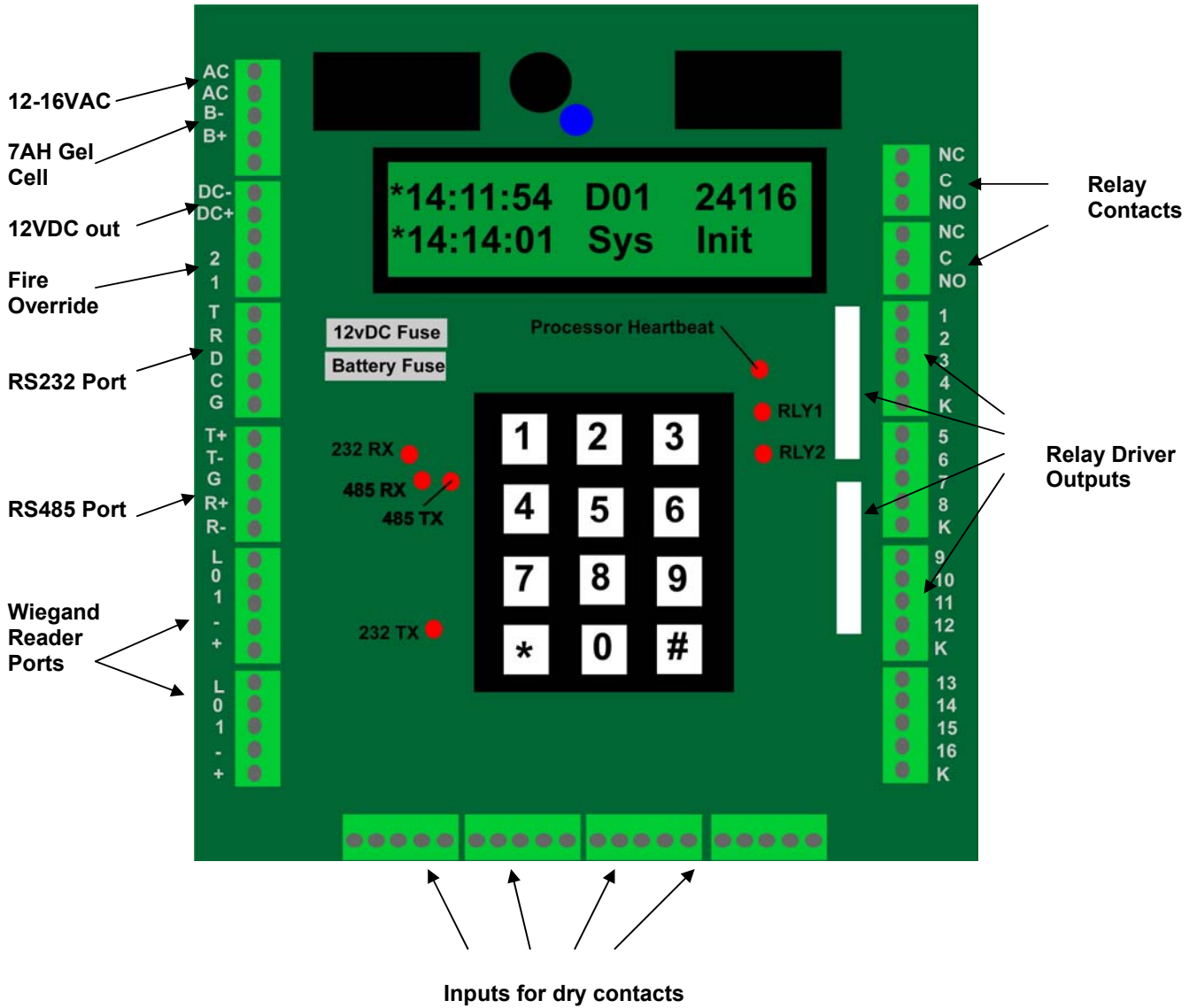

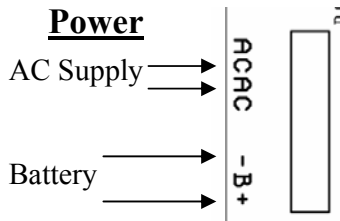

Supply

The I-PASS requires 12-16VAC at 1.5A connected to the AC terminals.

The I-PASS can charge a 7AH gel cell for battery backup purposes.

Connect the battery to the – and + terminals. The center terminal is not connected.

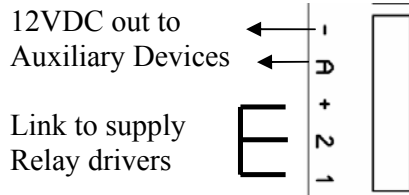

An auxiliary 12V output can supply up to 500mA to power door locks etc.

Connect auxiliary devices to – and A

Link 1 and 2 to + to supply the relay drivers. 1 supplies relay drivers 1 to 8, while 2 supplies relay drivers 9 to 16. These links can be interrupted for fire override.

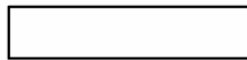

Inputs (if fitted)

Inputs are connected between the input terminal and C, and must be dry contacts.

C 1 2 3 4

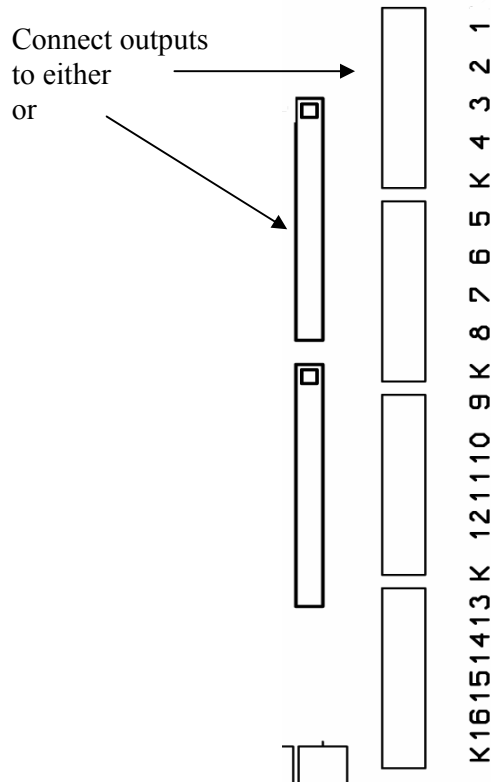

Relay Driver Outputs (if fitted)

Relays are connected between the output terminal and K. Either the terminal blocks or the pin header may be used. Relays may be directly connected without additional diode protection. Each output can sink up to 150mA.

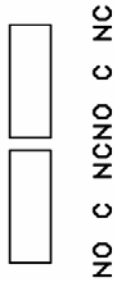

Relays

Two single pole changeover dry contact relays are provided.

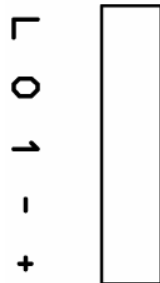

Reader Connection

Wiegand readers can be connected to these terminals. Connect D0 to the 0 terminal and D1 to the 1 terminal. The L terminal can be used to control the LED line. If RS485 readers are used, 12VDC supply of up to 500mA can be drawn from the - and + terminals

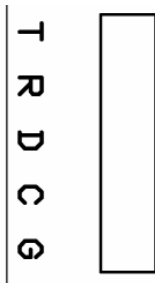

RS232 Connection

The I-PASS may be connected to a PC to back up or reload the data or audit trail, or to a serial printer, through the RS232 port. The connections are:

- T Transmit Data
- R Receive Data
- D Data Terminal Ready
- C Clear to Send (Printer only)
- G Signal Ground

To RS485 readers and DIDOs

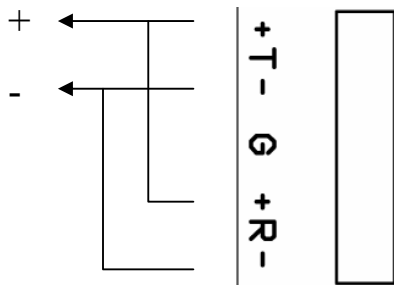

RS485 Bus

The RS485 bus is used to communicate between the I-PASS controller and the proximity readers and DIDO modules. Connect the T+ and R+ terminals of the controller to the 4R+ terminal of the reader or DIDO module, and the T- and R- terminal of the controller to the 4R- terminal of the reader or DIDO. Reader power of 12VDC at up to 500mA can be drawn from the Wiegand reader connections (see above).

